

Energizer®



CORDLESS PRUNING SAW

EZ20VELN

USER GUIDE

CAUTION: Read this manual before using this machine!

Energizer®

©2023 Energizer. Energizer and certain graphic designs are trademarks of Energizer Brands, LLC and related subsidiaries and are used under license by Builder SAS. All other brand names are trademarks of their respective owners. Neither Builder SAS nor Energizer Brands, LLC is affiliated with the respective owners of their trademarks.

Let's get started.

You're excited to power up, so we'll keep this brief!

CONTENTS

1. SAFETY INSTRUCTIONS.....	5
2. YOUR PRODUCT.....	12
3. FUNCTIONAL DESCRIPTION.....	12
4. ASSEMBLY.....	13
5. OPERATION.....	15
6. MAINTENANCE AND STORAGE.....	18
7. TECHNICAL DETAILS.....	21
8. DISPOSAL.....	22
9. DECLARATION OF CONFORMITY.....	23
10. WARRANTY.....	24
11. PRODUCT FAILURE.....	25
12. WARRANTY EXCLUSIONS.....	26

1. SAFETY INSTRUCTIONS

1.1 GENERAL POWER TOOL SAFETY WARNINGS

⚠ WARNING! Read all safety warnings, instructions, illustrations and specifications provided with this power tool. *Failure to follow all instructions listed below may result in electric shock, fire and/or serious injury.*

Save all warnings and instructions for future reference.

The term "power tool" in the warnings refers to your mains-operated (corded) power tool or battery-operated (cordless) power tool.

1) Work area safety

- a) **Keep work area clean and well lit.** *Cluttered or dark areas invite accidents.*
- b) **Do not operate power tools in explosive atmospheres, such as in the presence of flammable liquids, gases or dust.** *Power tools create sparks which may ignite the dust or fumes.*
- c) **Keep children and bystanders away while operating a power tool.** *Distractions can cause you to lose control.*

2) Electrical safety

- a) **Power tool plugs must match the outlet. Never modify the plug in any way. Do not use any adapter plugs with earthed (grounded) power tools.** *Unmodified plugs and matching outlets will reduce risk of electric shock.*
- b) **Avoid body contact with earthed or grounded surfaces, such as pipes, radiators, ranges and refrigerators.** *There is an increased risk of electric shock if your body is earthed or grounded.*
- c) **Do not expose power tools to rain or wet conditions.** *Water entering a power tool will increase the risk of electric shock.*
- d) **Do not abuse the cord. Never use the cord for carrying, pulling or unplugging the power tool. Keep cord away from heat, oil, sharp edges or moving parts.** *Damaged or entangled cords increase the risk of electric shock.*
- e) **When operating a power tool outdoors, use an extension cord suitable for outdoor use.** *Use of a cord suitable for outdoor use reduces the risk of electric shock.*
- f) **If operating a power tool in a damp location is unavoidable, use a residual current device (RCD) protected supply.** *Use of an RCD reduces the risk of electric shock.*

3) Personal safety

- a) **Stay alert, watch what you are doing and use common sense when operating a power tool. Do not use a power tool while you are tired or under the influence of drugs, alcohol or medication.** *A moment of inattention while operating power tools may result in serious personal injury.*
- b) **Use personal protective equipment. Always wear eye protection.** *Protective equipment such as a dust mask, non-skid safety shoes, hard hat or hearing protection used for appropriate conditions will reduce personal injuries.*
- c) **Prevent unintentional starting. Ensure the switch is in the off-position before connecting to power source and/or battery pack, picking up or carrying the tool.** *Carrying power tools with your finger on the switch or energising power tools that have the switch on invites accidents.*
- d) **Remove any adjusting key or wrench before turning the power tool on.** *A wrench or a key*

left attached to a rotating part of the power tool may result in personal injury.

- e) **Do not overreach. Keep proper footing and balance at all times.** *This enables better control of the power tool in unexpected situations.*
- f) **Dress properly. Do not wear loose clothing or jewelry. Keep your hair and clothing away from moving parts.** *Loose clothes, jewelry or long hair can be caught in moving parts.*
- g) **If devices are provided for the connection of dust extraction and collection facilities, ensure these are connected and properly used.** *Use of dust collection can reduce dust-related hazards.*
- h) **Do not let familiarity gained from frequent use of tools allow you to become complacent and ignore tool safety principles.** *A careless action can cause severe injury within a fraction of a second.*

4) Power tool use and care

- a) **Do not force the power tool. Use the correct power tool for your application.** *The correct power tool will do the job better and safer at the rate for which it was designed.*
- b) **Do not use the power tool if the switch does not turn it on and off.** *Any power tool that cannot be controlled with the switch is dangerous and must be repaired.*
- c) **Disconnect the plug from the power source and/or remove the battery pack, if detachable, from the power tool before making any adjustments, changing accessories, or storing power tools.** *Such preventive safety measures reduce the risk of starting the power tool accidentally.*
- d) **Store idle power tools out of the reach of children and do not allow persons unfamiliar with the power tool or these instructions to operate the power tool.** *Power tools are dangerous in the hands of untrained users.*
- e) **Maintain power tools and accessories. Check for misalignment or binding of moving parts, breakage of parts and any other condition that may affect the power tool's operation.** *If damaged, have the power tool repaired before use. Many accidents are caused by poorly maintained power tools.*
- f) **Keep cutting tools sharp and clean.** *Properly maintained cutting tools with sharp cutting edges are less likely to bind and are easier to control.*
- g) **Use the power tool, accessories and tool bits etc. in accordance with these instructions, taking into account the working conditions and the work to be performed.** *Use of the power tool for operations different from those intended could result in a hazardous situation.*
- h) **Keep handles and grasping surfaces dry, clean and free from oil and grease.** *Slippery handles and grasping surfaces do not allow for safe handling and control of the tool in unexpected situations.*

5) Battery tool use and care

- a) **Recharge only with the charger specified by the manufacturer.** *A charger that is suitable for one type of battery pack may create a risk of fire when used with another battery pack.*
- b) **Use power tools only with specifically designated battery packs.** *Use of any other battery packs may create a risk of injury and fire.*
- c) **When battery pack is not in use, keep it away from other metal objects, like paper clips, coins, keys, nails, screws or other small metal objects, that can make a connection from one terminal to another.** *Shorting the battery terminals together may cause burns or a fire.*
- d) **Under abusive conditions, liquid may be ejected from the battery; avoid contact. If contact accidentally occurs, flush with water. If liquid contacts eyes, additionally seek medical help.** *Liquid ejected from the battery may cause irritation or burns.*
- e) **Do not use a battery pack or tool that is damaged or modified.** *Damaged or modified*

batteries may exhibit unpredictable behaviour resulting in fire, explosion or risk of injury.

f) Do not expose a battery pack or tool to fire or excessive temperature. *Exposure to fire or temperature above 130°C may cause explosion.*

g) Follow all charging instructions and do not charge the battery pack or tool outside the temperature range specified in the instructions. *Charging improperly or at temperatures outside the specified range may damage the battery and increase the risk of fire.*

6) Service

a) Have your power tool serviced by a qualified repair person using only identical replacement parts. *This will ensure that the safety of the power tool is maintained.*

b) Never service damaged battery packs. *Service of battery packs should only be performed by the manufacturer or authorized service providers.*

1.2 SAFETY INSTRUCTIONS FOR PRUNING SAW

1) General chain saw safety warnings:

a) Keep all parts of the body away from the saw chain when the chain saw is operating. *Before you start the chain saw, make sure the saw chain is not contacting anything. A moment of inattention while operating chain saws may cause entanglement of your clothing or body with the saw chain.*

b) Always hold the chain saw with your right hand on the rear handle and your left hand on the front handle. *Holding the chain saw with a reversed hand configuration increases the risk of personal injury and should never be done.*

c) Hold the chain saw by insulated gripping surfaces only, because the saw chain may contact hidden wiring. *Saw chains contacting a "live" wire may make exposed metal parts of the chain saw "live" and could give the operator an electric shock.*

d) Wear eye protection. Further protective equipment for hearing, head, hands, legs and feet is recommended. *Adequate protective equipment will reduce personal injury from flying debris or accidental contact with the saw chain.*

e) Do not operate a chain saw in a tree, on a ladder, from a rooftop, or any unstable support. *Operation of a chain saw in this manner could result in serious personal injury.*

f) Always keep proper footing and operate the chain saw only when standing on fixed, secure and level surface. *Slippery or unstable surfaces may cause a loss of balance or control of the chain saw.*

g) When cutting a limb that is under tension, be alert for spring back. *When the tension in the wood fibers is released, the spring loaded limb may strike the operator and/or throw the chain saw out of control.*

h) Use extreme caution when cutting brush and saplings. *The slender material may catch the saw chain and be whipped toward you or pull you off balance.*

i) Carry the chain saw by the front handle with the chain saw switched off and away from your body. When transporting or storing the chain saw, always fit the guide bar cover. *Proper handling of the chain saw will reduce the likelihood of accidental contact with the moving saw chain.*

j) Follow instructions for lubricating, chain tensioning and changing the bar and chain. *Improperly tensioned or lubricated chain may either break or increase the chance for kickback.*

k) Cut wood only. Do not use chain saw for purposes not intended. For example: do not use chain saw for cutting metal, plastic, masonry or non-wood building materials. Use of the chain saw for operations different than intended could result in a hazardous situation.

- l) **Do not attempt to fell a tree until you have an understanding of the risks and how to avoid them.** *Serious injury could occur to the operator or bystanders while felling a tree.*
- m) **This chain saw is not intended for tree felling.** *Use of the chain saw for operations different than intended could result in serious injury to the operator or bystanders.*

2) Causes and operator prevention of kickback

- Kickback may occur when the nose or tip of the guide bar touches an object, or when the wood closes in and pinches the saw chain in the cut.
- Tip contact in some cases may cause a sudden reverse reaction, kicking the guide bar up and back towards the operator.
- Pinching the saw chain along the top of the guide bar may push the guide bar rapidly back towards the operator.
- Either of these reactions may cause you to lose control of the saw which could result in serious personal injury. Do not rely exclusively upon the safety devices built into your saw.
- As a chain saw user, you should take several steps to keep your cutting jobs free from accident or injury.
- Kickback is the result of chain saw misuse and/or incorrect operating procedures or conditions and can be avoided by taking proper precautions as given below:
 - a) **Maintain a firm grip, with thumbs and fingers encircling the chain saw handles, with both hands on the saw and position your body and arm to allow you to resist kickback forces.** *Kickback forces can be controlled by the operator, if proper precautions are taken. Do not let go of the chain saw.*
 - b) **Do not overreach and do not cut above shoulder height.** *This helps prevent unintended tip contact and enables better control of the chain saw in unexpected situations.*
 - c) **Only use replacement guide bars and saw chains specified by the manufacturer.** *Incorrect replacement guide bars and saw chains may cause chain breakage and/or kickback.*
 - d) **Follow the manufacturer's sharpening and maintenance instructions for the saw chain.** *Decreasing the depth gauge height can lead to increased kickback.*

3) General chain saw safety warnings

- a) **Follow all instructions when clearing jammed material, storing or servicing the chain saw.** *Make sure the switch is off and the battery pack is removed. Unexpected actuation of the chain saw while clearing jammed material or servicing may result in serious personal injury.*

1.3 ADDITIONAL INSTRUCTIONS

- First-time user should, as a minimum, practice cutting logs on a saw-horse or cradle.
- Wear protective gloves, protective helmet, eye protection, hearing protection and a protective mask.
- This chain saw is not suitable for tree felling.
- Do not operate the chain saw without lubrication. Use a lubricant for lubricating the blade. Use only recommended lubricants (ask advice to your dealer or our service agent).

1.4 SPECIAL SAFETY INSTRUCTIONS FOR BATTERY-OPERATED TOOLS

- 1) Ensure that the tool is switched off before inserting the battery. Inserting a battery into a tool that is switched on may result in accidents.
- 2) Recharge the batteries indoors only because the battery charger is designed for indoor use only. Risk of electric shock.

- 3) To reduce the electric shock hazard, unplug the battery charger from the mains before cleaning the charger.
- 4) Do not subject the battery to strong sunlight over long periods and do not leave it on a heater. Heat damages the battery and there is risk of explosion.
- 5) Allow a hot battery to cool before charging.
- 6) Do not open up the battery and avoid mechanical damage to the battery. Risk of short circuit and fumes may be emitted that irritate the respiratory tract. Ensure fresh air and seek medical assistance in the event of discomfort.
- 7) Do not use a non-rechargeable battery. This could damage the appliance.
- 8) The recommended ambient temperature range for the charging system during charging is from 4°C to 40°C.
- 9) The recommended ambient temperature range for tool and battery storage is from 0°C to 50°C.
- 10) The recommended ambient temperature range for tool and battery use is from -5°C to 50°C.
- 11) Remove the battery from the device before storage.
- 12) Electrolyte leaking from the cells can cause damage to the skin, clothes or any other items exposed to it. If the electrolyte contacts the skin or clothes, wash thoroughly with clean water. If the electrolyte enters into the eyes, do not rub the eyes but flush them immediately with copious amounts of clean water such as tap water, and immediately consult a doctor.
- 13) Do not disassemble or modify the battery, which can cause short-circuiting between cells or between the cell and its wiring, and disables the battery's safety protection system. These can lead to electrolyte leakage, overheating or a cell or battery, bursting and fire.
- 14) Avoid casual or inadvertent shorting of a battery with metallic objects such as: wire, tools, neckless or hairpins, which can cause short-circuiting, which cause excess current flow, electrolyte leakage, heating of cells or batteries, bursting and fire.
- 15) Keep battery away from a fire or heat. The insulation materials will melt and the gas release vent and protection system will be damaged, causing electrolyte leakage, bursting and possibly fire.
- 16) Not allow the battery to make contact with water or get wet, it may short-circuit, overheat, rust or lose its functions.
- 17) Do not expose the battery to mechanical shock, for example, by dropping, throwing or crushing, causing electrolyte leakage, cell and battery heating, bursting and fire.
- 18) Avoid directly connecting the battery to a electric source such as a 12V car charger, or car battery, which may cause excess current to flow at high voltage and can cause electrolyte leakage, overheating of a cell or battery, bursting and fire.

1.5 SAFETY INSTRUCTIONS FOR CHARGER

1) This charger can be used by children aged from 8 years and above and persons with reduced physical, sensory or mental capabilities or lack of experience and knowledge if they have been given supervision or instruction concerning use of the charger in the

safe way and understand the hazards involved.

Children shall not play with the charger. Cleaning and user maintenance of the charger shall not be made by children without adult supervision.

2) If the supply cord is damaged, it must be replaced by the manufacturer, its service agent or similarly qualified persons in order to avoid a hazard.

3) To charge the battery, use only the charger supplied.

4) Never charge non-rechargeable batteries.

5) During charging the batteries must be placed in a well ventilated area.

1.6 VIBRATION AND NOISE REDUCTION

To reduce the impact of noise and vibration emission, limit the time of operation, use low-vibration and low noise operating modes as well as wear personal protective equipment.

Take the following points into account to minimize the vibration and noise exposure risks:

- 1) Only use the product as intended by its design and these instructions.
- 2) Ensure that the product is in good condition and well maintained.
- 3) Use correct attachments for the product and ensure they are in good condition.
- 4) Keep tight grip on the handles surface.
- 5) Plan your work schedule to spread any high vibration tool use across a longer period of time.

1.7 RESIDUAL RISK

Even if properly operating and handling this product in accordance with all the safety requirements, potential risks of injury and damage remain. Due to its construction and build, this tool may present the following hazards:

- 1) Electric shock from insufficient insulation. Do not use the product when the product or your hands are damp or wet.
- 2) Ear damage if working without ear protection.
- 3) There is a risk of a short-circuit due to liquid penetrating the housing. Do not immerse the product and the accessories in water. And make sure that no water or other liquid can enter the housing.
- 4) Damage to your health caused by swinging your hands and arms when operating the tool for longer periods of time or if the tool is not held or maintained properly.

⚠ WARNING! During operating, the product generates an electromagnetic field which, under certain circumstances, may impair the functionality of active or passive medical implants. To reduce

the risk of serious or lethal injuries, we recommend that persons with medical implants consult their doctor and the manufacturer of their medical implant before operating the electric tool.

1.8 SYMBOLS

! WARNING! This chain-saw is for use by trained tree service operations only. Use without proper training can result in severe injuries. See instructions!

	<p>Conforms to relevant safety standards.</p>
 	<p>To reduce the risk of injury, the user must read and understand this manual before using this product.</p>
	<p>Appropriate ear, eye, and head protection must be worn.</p>
	<p>Use appropriate protection for foot-leg and hand-arm.</p>
	<p>This chain-saw is for trained tree service operators only.</p>
	<p>Beware of chain saw kickback and avoid contact with bar tip.</p>
	<p>Always use chain saw with both hands.</p>
	<p>Do not operate chain saw one-handed.</p>
	<p>Do not expose to rain.</p>
	<p>Do not dispose of old appliances with domestic rubbish.</p>
	<p>Guarantee sound power level.</p>

2. YOUR PRODUCT

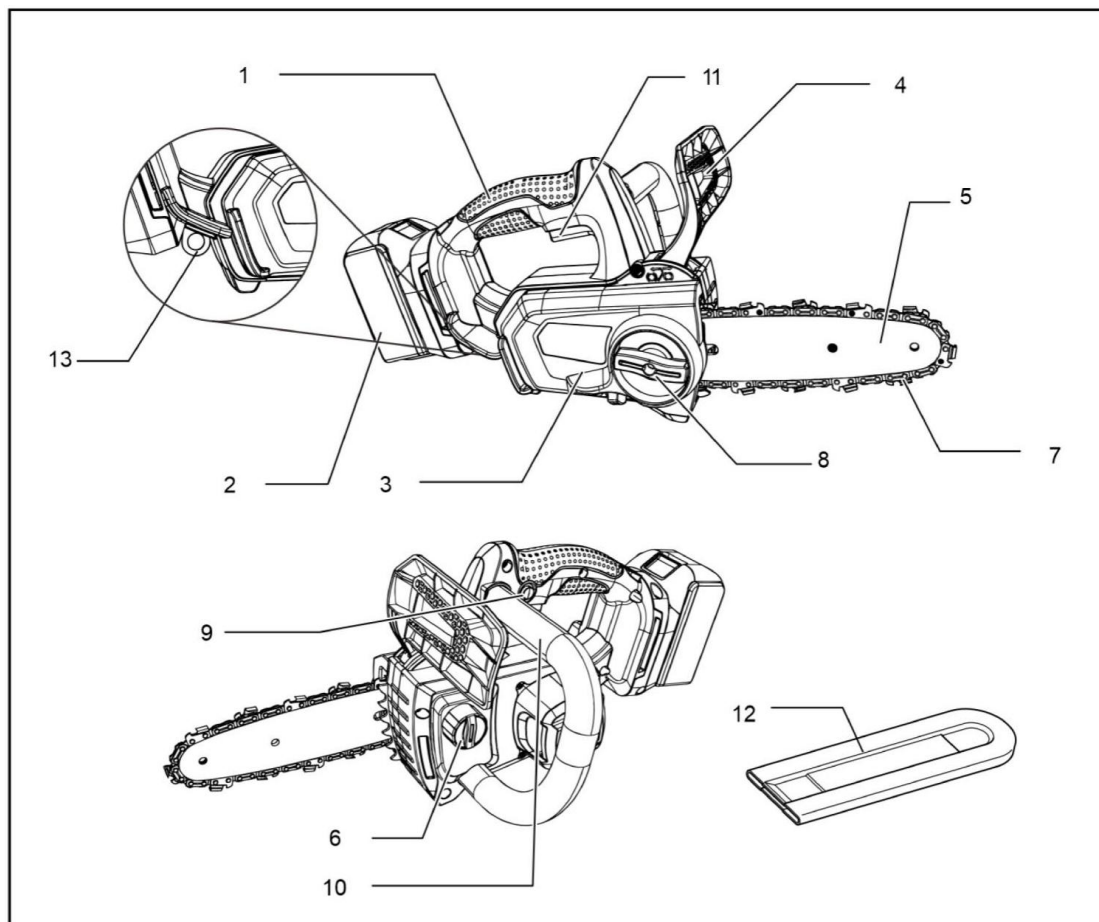

- | | | |
|----------------------|--------------------|--|
| 1) Top handle | 6) Oil tank cover | 11) Switch trigger |
| 2) Battery cartridge | 7) Saw chain | 12) Chain cover (scabbard) |
| 3) Sprocket cover | 8) Knob | 13) Carabiner or rope attachment point |
| 4) Front hand guard | 9) Lock off button | |
| 5) Guide bar | 10) Front handle | |

3. FUNCTIONAL DESCRIPTION

⚠ WARNING! Always be sure that the tool is switched off and the battery is removed before adjusting or checking function on the tool.

3.1 TOOL / BATTERY PROTECTION SYSTEM

The tool is equipped with a tool/battery protection system. This system automatically cuts off power to the motor to extend tool and battery life. The tool will automatically stop during operation if the tool or battery is placed under one of the following conditions.

1) Overload protection

The tool is operated in a manner that causes it to draw an abnormally high current.

In this situation, release the trigger switch on the tool and stop the application that caused the tool to become overloaded. Then pull the trigger switch again to restart.

If the tool does not start, the battery is overheated. In this situation, let the battery cool before pulling the trigger switch again.

2) Low voltage battery

The remaining battery capacity is too low and the tool will not operate. In this situation, remove and recharge the battery.

3) Switch action

⚠ WARNING! Before inserting the battery into the tool, always check that the switch trigger actuates properly and returns to the "OFF" position when released.

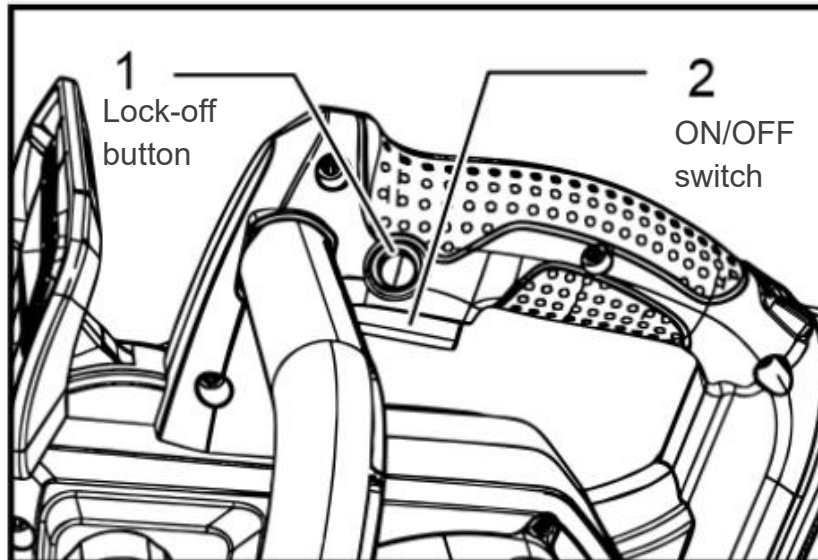

To prevent the switch trigger from being accidentally pulled, a lock-off button is provided.

To start the tool, depress the lock-off button and pull the switch trigger. Release the switch trigger to stop.

4. ASSEMBLY

⚠ WARNING! Always be sure that the tool is switched off and the battery is removed before assembling the tool.

4.1 INSTALLING OR REMOVING SAW CHAIN

⚠ WARNING! Always wear gloves when installing or removing the saw chain.

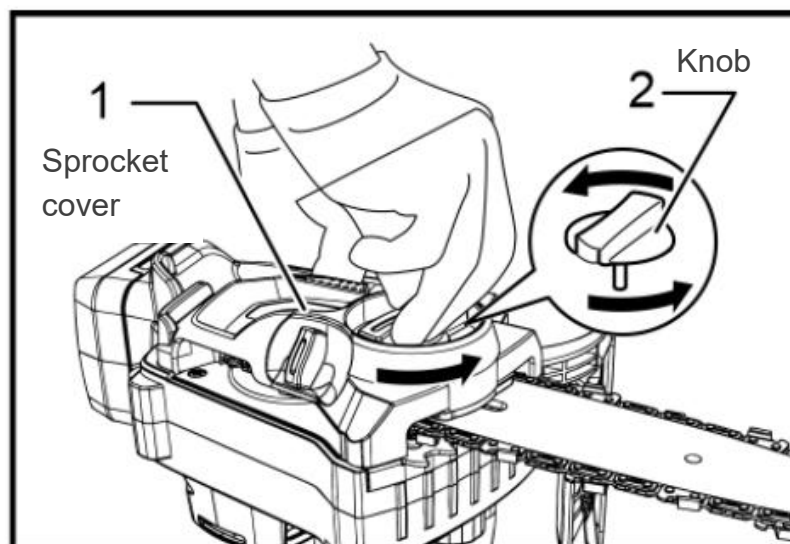

- Loosen the screw by turning the knob counterclockwise until the sprocket cover comes off.

- Remove the sprocket cover.
- Remove saw chain and guide bar from the tool.

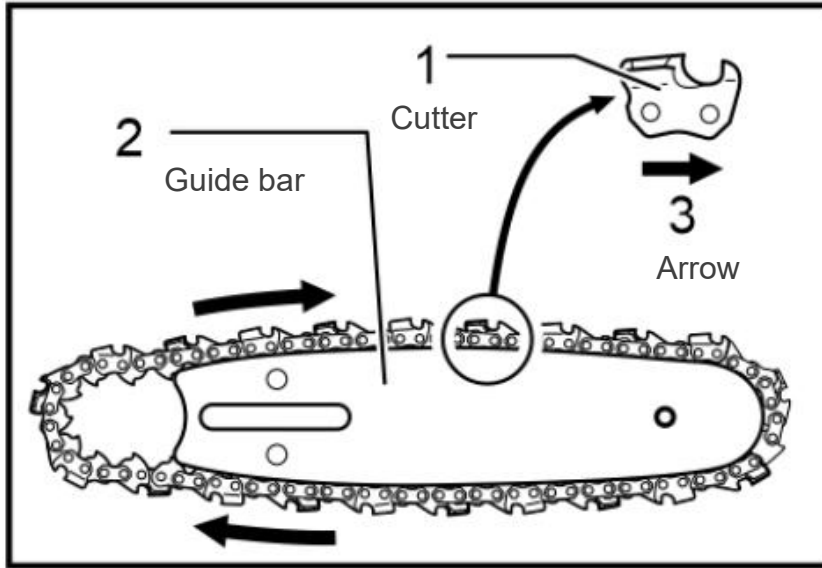

- Fit in one end of the saw chain on the top of guide bar.
- At this time, fit the saw chain as shown in the figure above because it rotates in the direction of arrow.

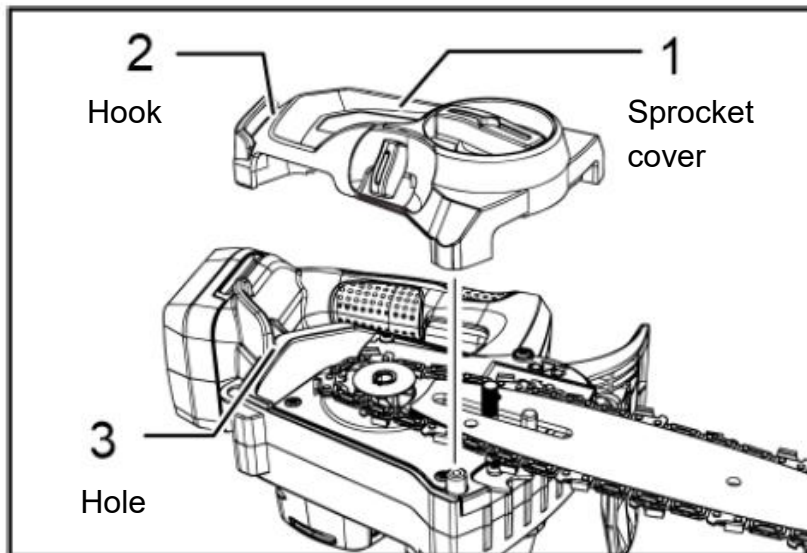

- Insert the hook of sprocket cover into the hole and then place the sprocket cover on the tool.

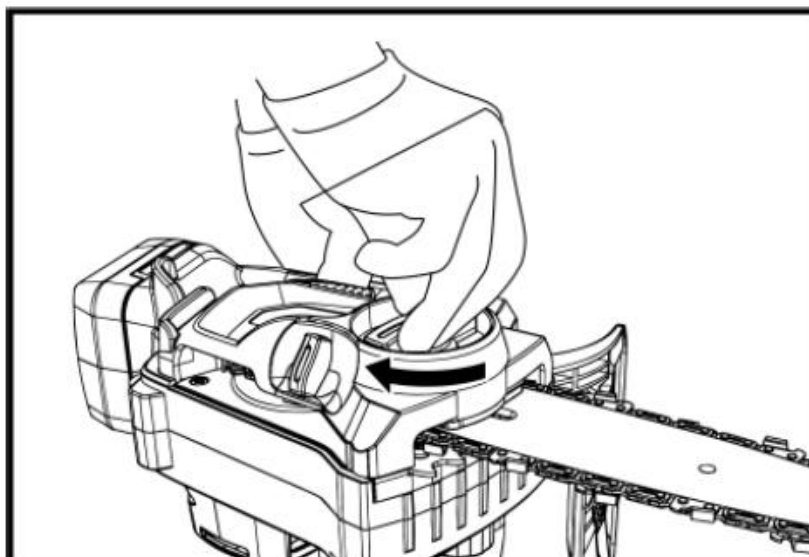

- Turn the knob clockwise to tighten the screw firmly.

4.2 ADJUSTING SAW CHAIN TENSION

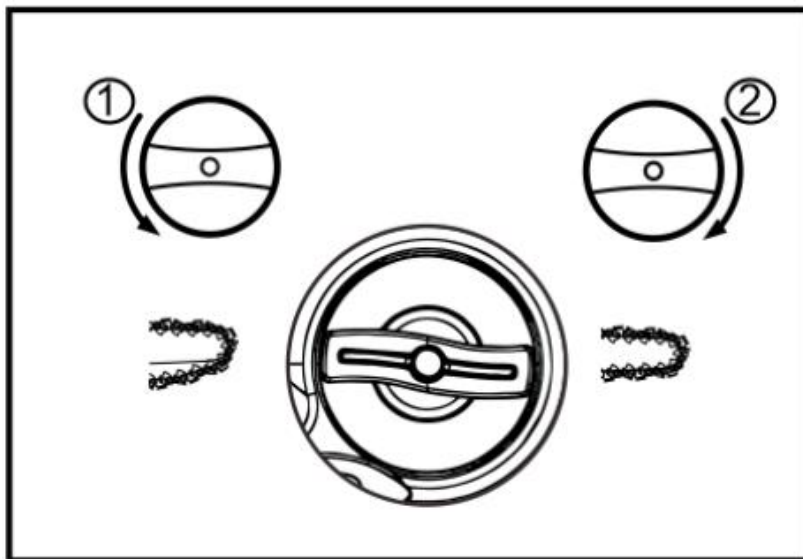

- Just a slight loosening of the screw allows the saw chain tension to be adjusted. After adjusting, retighten the screw firmly.

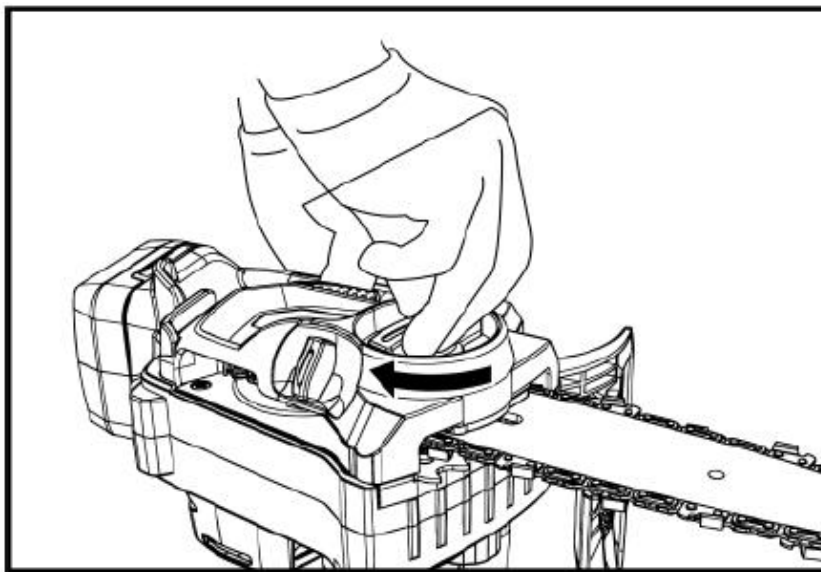

5. OPERATION

5.1 LUBRICATION

- Saw chain is automatically lubricated when the tool is in operation. Check the amount of remaining oil in the oil tank periodically.
- Check the amount of remaining oil in the oil tank through the oil inspection window.
- To refill the tank, remove the cap from the oil tank opening. The oil tank capacity is 100 ml.
- After refilling the tank, always screw the provided oil tank cap on the chain saw.

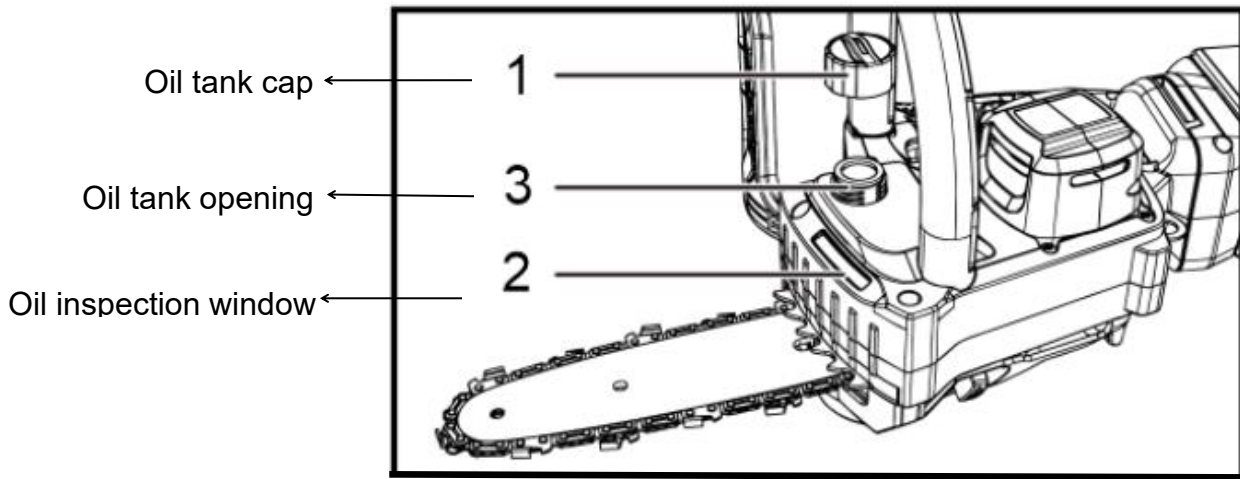

! WARNING!

- When filling the chain saw with chain oil for the first time, or refilling the tank after it has been completely emptied, add oil up to the bottom edge of the filler neck. The oil delivery may otherwise be impaired.
- Never use oil including dust and particles or volatile oil.
- When pruning trees, use botanical oil. Mineral oil may harm trees.
- Never force the chain saw when pruning trees.
- Before cutting out, make sure that the provided oil tank cap is screwed in place.
- Hold the chain saw away from the tree. Start it and wait until lubrication on saw chain is adequate.
- Bring the tip guide/lower guide into contact with the branch to be cut before switching on. Cutting without bringing the tip guide/lower guide into contact with the branch may cause the guide bar to wobble, resulting in injury to operator.
- Saw the wood to be cut by just moving it down.

5.2 PRUNING TREES

! WARNING!

- Keep all parts of the body away from the saw chain when the motor is operating.
- Hold the chain saw firmly with both hands when the motor is running.
- Do not overreach. Keep proper footing and balance at all times.

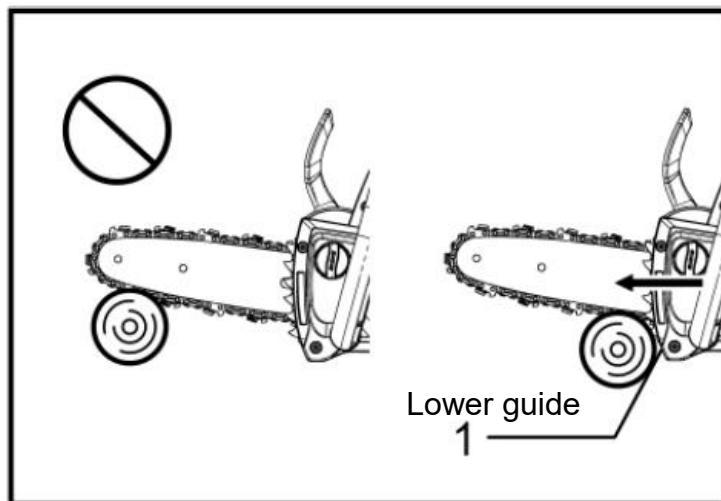

- Bring the lower guide into contact with the branch to be cut before switching on. Cutting without bringing the lower guide into contact with the branch may cause the guide bar to wobble,

resulting in injury to operator.

- When cutting thick branches, first make a shallow undercut and then make the finish cut from the top.

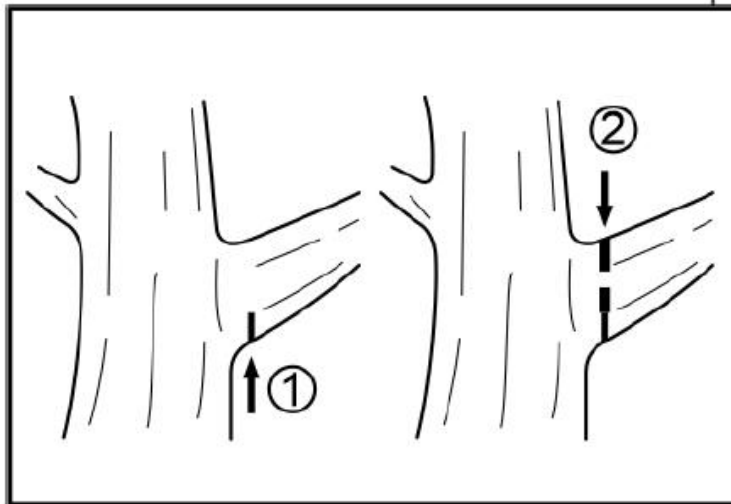

- If you try to cut off thick branches from the bottom, the branch may close in and pinch the saw chain in the cut.
- If you try to cut off thick branches from the top without a shallow undercut, the branch may splinter.

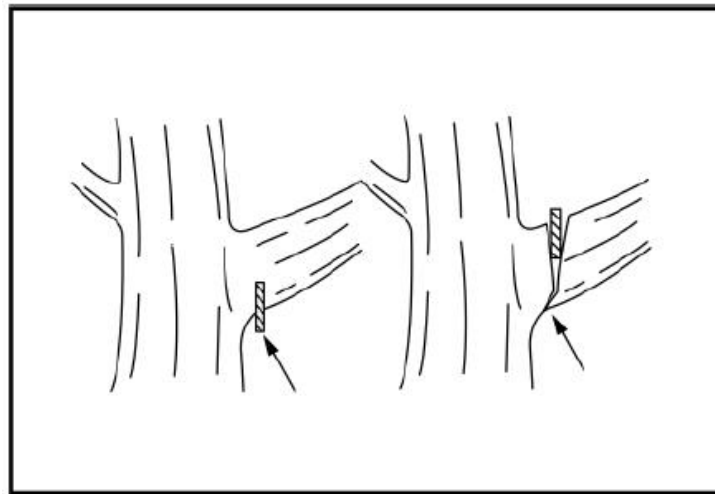

- If you cannot cut the timber right through with a single stroke:
Apply light pressure to the handle and continue sawing and draw the chain saw back a little;
then apply the spike a little lower and finish the cut by raising the handle.

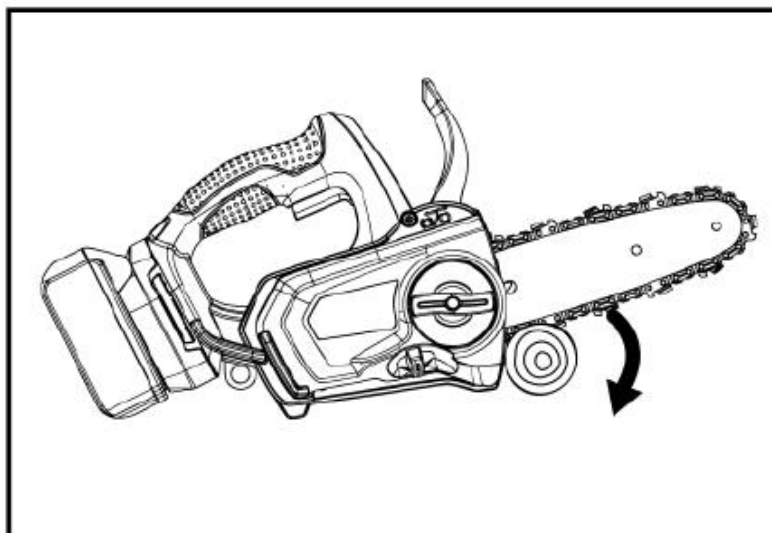

5.3 CARRYING TOOL

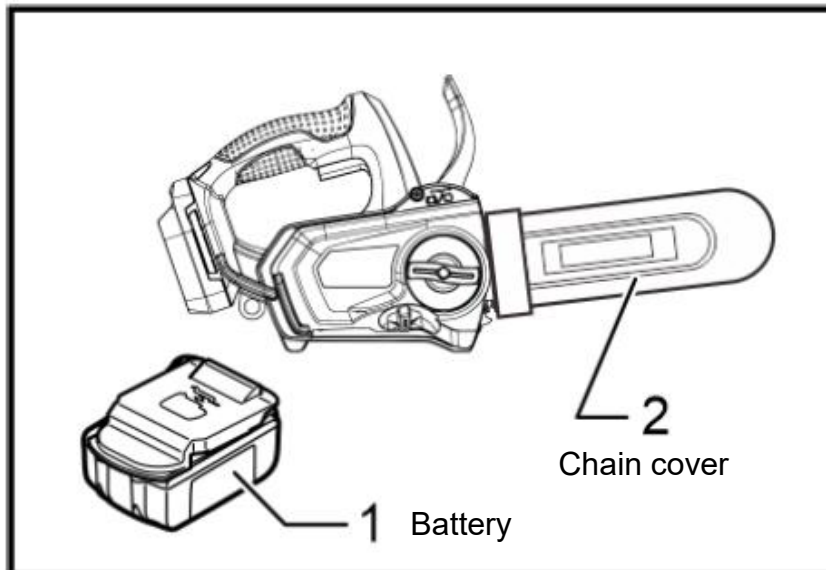

Always remove the battery cartridge from the tool and overlap the guide bar with the scabbard before carrying the tool. Also cover the battery cartridge with the battery cover.

6. MAINTENANCE & STORAGE

6.1 MAINTENANCE

! WARNING!

- Always be sure that the tool is switched off and the battery cartridge is removed before attempting to perform inspection or maintenance.
- Always wear gloves when performing any inspection or maintenance.
- Never use gasoline, benzine, thinner, alcohol or the like. Discoloration, deformation or cracks may result.

1) Sharpening the saw chain

! **WARNING!** Always remove the battery and wear safety gloves when performing work on the saw chain.

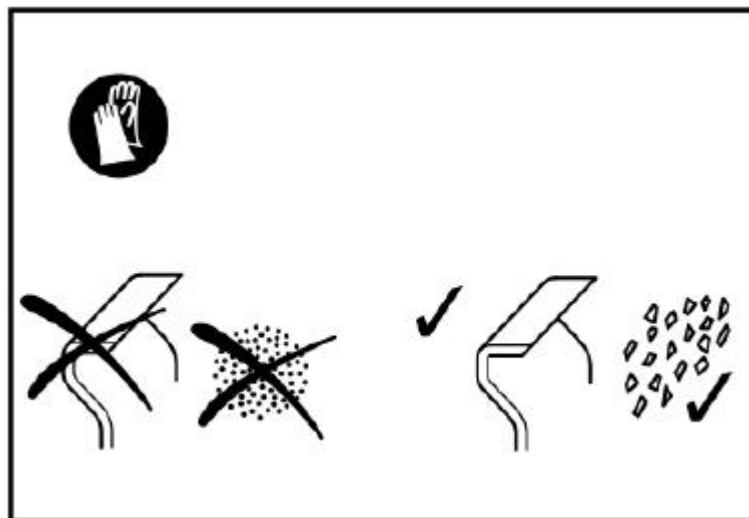

The chain must be sharpened when:
- Wood chips have become powder.

- The cut is not straight.
- Vibration increase.
- Fuel consumption has increased.

Sharpen the saw chain frequently, but remove only a little material each time.

Two or three strokes with a file are usually sufficient for routine resharpening. When the saw chain has been resharpened several times, have it sharpened in a specialist repair shop.

2) File and file guiding

- Use a special round file for saw chains, with a diameter of 4 mm, to sharpen the chain. Normal round files are not suitable.
- The file should only engage the material on the forward stroke. Lift the file off the material on the return stroke.
- Sharpen the shortest cutter first. The length of this cutter is then the gauge dimension for all other cutters on the saw chain.
- Guide the file as shown in the figure.
- The file can be guided more easily if a file holder (accessory) is employed. The file holder has markings for the correct sharpening angle of 30° (align the markings parallel to the saw chain) and limits the depth of penetration (to 4/5 of the file diameter).

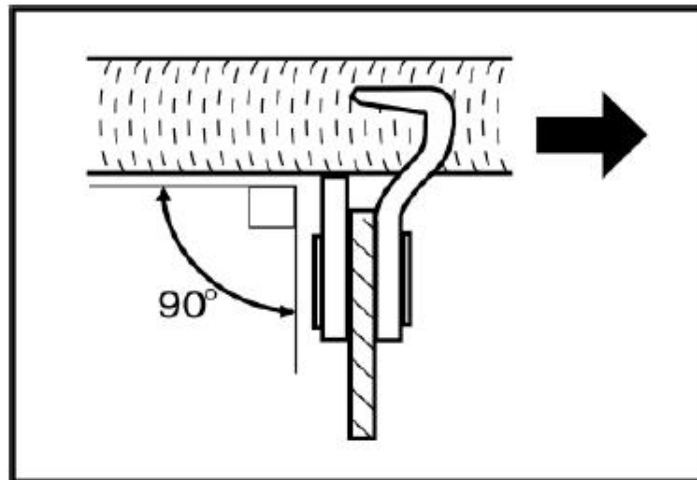

Guide the file as shown in the figure.

- After sharpening the chain, check the height of the depth gauge using the chain gauge tool (optional accessory).

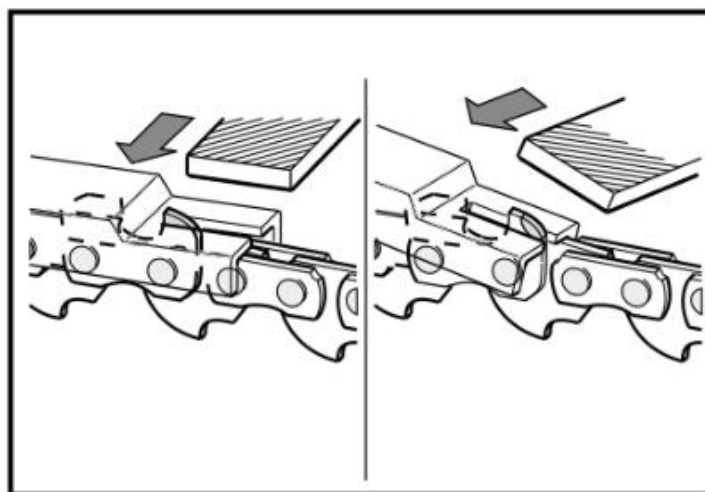

- Remove any projecting material, however small, with a special flat file (optional accessory).
- Round off the front of the depth gauge again.
- Wash away dust and particles from saw chain after adjusting the height of depth gauge.

3) Cleaning guide bar

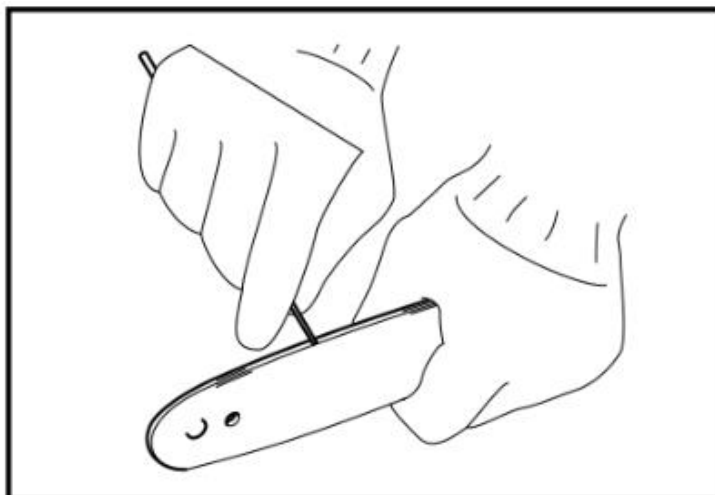

Chips and sawdust will build up in the guide bar groove, clogging it and impairing oil flow. Always clean out the chips and sawdust when sharpening or replacing the saw chain.

4) Replacing the sprocket

Before fitting a new saw chain, check the condition of the sprocket.

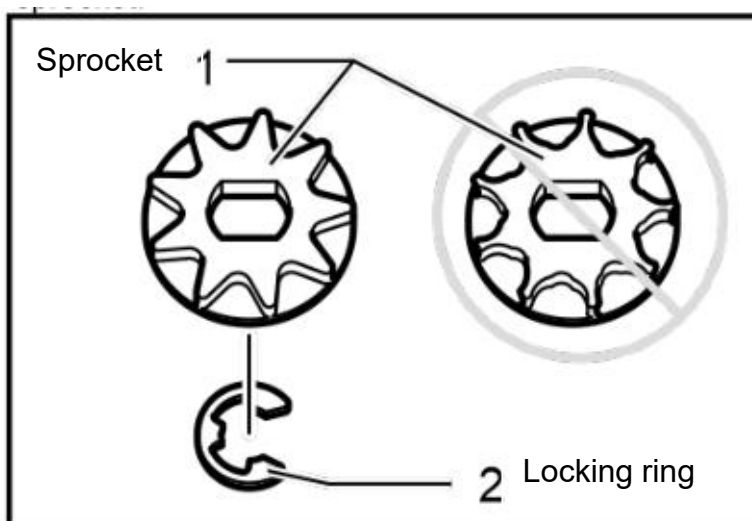

⚠ WARNING! A worn sprocket will damage a new saw chain. Have the sprocket replaced in this case. The sprocket needs to be installed so that it always faces as shown in the figure.

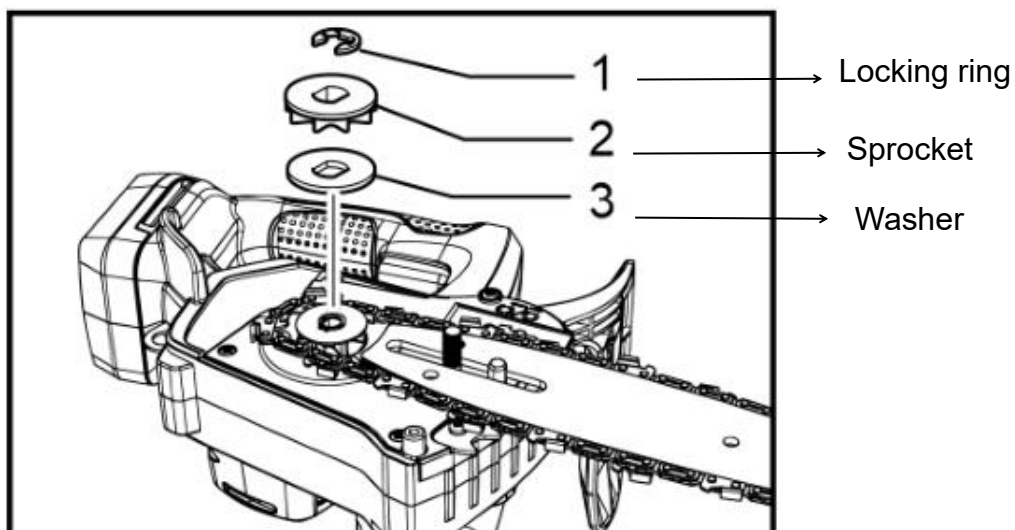

Always fit a new locking ring when replacing the sprocket.

6.2 STORAGE

Clean the tool before storing. Remove any chips and sawdust from the tool after removing the sprocket cover.

After cleaning the tool, run it under no load to lubricate the saw chain and guide bar.

Cover the guide bar with the scabbard.

Remove oil from the oil tank to empty it and place the chain saw with the tank cap facing upward.

6.3 OPTIONAL ACCESSORIES

⚠ WARNING! These accessories or attachments are recommended for use with your tool specified in this manual. The use of any other accessories or attachments might present a risk of injury to persons. Only use accessory or attachment for its stated purpose.

If you need any assistance for more details regarding these accessories, ask your local Service Center.

- Saw chain
- Guide bar
- Guide bar cover
- File
- Tool bag

⚠ WARNING! If you purchase a guide bar of different length from the standard guide bar, also purchase a suitable guide bar cover together. It must fit and fully cover the guide bar on the chain saw.

7. TECHNICAL DATA

Rated voltage	20V d.c.
Motor type	Brushless
Cutting capacity	17.5cm
Chain speed	7m/s
Oil tank	100 ml
Unit mass (without guide bar and chain, empty tanks)	2.3kg
Guide bar type	AP08-33-507P (8")
Chain saw type	3/8LP-33 (8")
Battery type	Recommendation of battery to use: Model: EZB2A or EZB4A 20V d.c. 2Ah or 4Ah
Charger type	Recommendation of charger to use: Model: EZCR20V-1 Input 220-240V~ 50/60Hz, 65W Output 21V d.c., 2.5A
Sound pressure level	Max. LpA =81.3 dB(A), K= 3 dB(A)
Sound power level	Max. LwA =95.7 dB(A), K= 3 dB(A)
Guarantee sound power level	99dB(A)
Vibrations Ah _{AG}	Max. ah _{AG} =3 m/s ² , K=1,5 m/s ²

INFORMATION

- The declared vibration total value has been measured in accordance with a standard test method and may be used for comparing one tool with another.
- The declared vibration total value may also be used in a preliminary assessment of exposure.

WARNING!

- The vibration emission during actual use of the power tool can differ from the declared total value depending on the ways in which the tool is used.
- There is a need to identify safety measures to protect the operator that are based on an estimation of exposure in the actual conditions of use (taking account of all parts of the operating cycle such as the times when the tool is switched off and when it is running idle in addition to the trigger time).
- Wear hearing protection.

8. DISPOSAL



Electrical products should not be discarded with household products. According to the European Directive 2012/19/EU on waste electrical and electronic equipment and its implementation into national law, electrical products used must be collected separately and disposed of at collection points provided for this purpose. Talk with your local authorities or dealer for advice on recycling.

BATTERY PACK



Li-ion

This product contains Li-ion. To preserve natural resources, please recycle or dispose of batteries properly. Local, state or federal laws may prohibit disposal of Li-ion batteries in ordinary trash. Consult you local waste authority for information regarding available recycling and/or disposal options.

9. DELARATION OF CONFORMITY



BUILDER SAS

32, rue Aristide Bergès - ZI 31270 Cugnaux - France,
declares that,

Product: Cordless PRUNING MACHINE

Trade mark: ENERGIZER

Model: EZ20VELN

Serial number: 20231108078-20231108427

Is in conformity with the essential requirements and other relevant provisions of the applicable European Directives, based on the application of European harmonized standards. Any unauthorized modification of the apparatus voids this declaration.

European Directives (including, if applicable, their amendments up to the date of signature);

Rohs directive 2011/65/EU + (EU) 2015/863

2014/30/EU;

2006/42/EC

European harmonized standards

EN 62841-1: 2015+AC:2015

EN 62841-4-1: 2020

EN ISO 11681-2 :2022

EN IEC55014-1:2021

EN IEC55014-2:2021

Cugnaux, 27/10/2023

Philippe MARIE / PDG

Responsible of the technical file: Mr Olivier Patriarca

10. WARRANTY

Energizer[®]

WARRANTY

The manufacturer guarantees the product against defects in material and workmanship for a period of 2 years from the date of the original purchase. The warranty only applies if the product is for household use. The warranty does not cover breakdowns due to normal wear and tear.

The manufacturer agrees to replace parts identified as defective by the designated distributor. The manufacturer does not accept responsibility for the replacement of the machine, in whole or in part, and/or ensuing damage.

The warranty does not cover breakdowns due to:

- insufficient maintenance.
- abnormal assembly, adjustment or operations of the product.
- parts subject to normal wear and tear.

The warranty does not extend to:

- shipping and packaging costs.
- using the tool for a purpose other than that for which it was designed.
- the use and maintenance of the machine done in a manner not described in the user manual.

Due to our policy of continuous product improvement, we reserve the right to alter or change specifications without notice. Consequently, the product may be different from the information contained therein, but a modification will be undertaken without notice if it is recognized as an improvement of the preceding characteristic.

READ THE MANUAL CAREFULLY BEFORE USING THE MACHINE.

When ordering spare parts, please indicate the part number or code, you can find this in the spare parts list in this manual. Keep the purchase receipt; without it, the warranty is invalid. To help you with your product, we invite you to contact us by phone or via our website:

- **+33 (0)9.70.75.30.30**
- **<https://services.swap-europe.com/contact>**

You must create a "ticket" via the web platform.

- Register or create your account.
- Indicate the reference of the tool.
- Choose the subject of your request.
- Describe your problem.
- Attach these files: invoice or sales receipt, photo of the identification plate (serial number), photo of the part you need (for example: pins on the transformer plug which are broken).



11. PRODUCT FAILURE

WHAT TO DO IF MY MACHINE BREAKS DOWN?

If you bought your product in a store:

- a) Empty the fuel tank if your product has one.
- b) Make sure that your machine is complete with all accessories supplied, and clean! If this is not the case, the repairer will refuse the machine.

Go to the store with the complete machine and with the receipt or invoice.

If you bought your product on a website:

- a) Empty the fuel tank if your product has one.
- b) Make sure that your machine is complete with all accessories supplied, and clean! If this is not the case, the repairer will refuse the machine.
- c) Create a SWAP-Europe service ticket on the site: <https://services.swap-europe.com>. When making the request on SWAP-Europe, you must attach the invoice and the photo of the nameplate (serial number).
- d) Contact the repair station to make sure it is available before dropping off the machine.

Go to the repair station with the complete machine packed, accompanied by the purchase invoice and the station support sheet downloadable after the service request is completed on the SWAP-Europe site.

For machines with engine failure from manufacturers BRIGGS & STRATTON, HONDA and RATO, please refer to the following instructions.

Repairs will be done by approved engine manufacturers of these manufacturers, see their site:

- <http://www.briggsandstratton.com/eu/fr>
- <http://www.honda-engines-eu.com/fr/service-network-page;jsessionid=5EE8456CF39CD572AA2AEEDFD290CDAE>
- <https://www.rato-europe.com/it/service-network>

Please keep your original packaging to allow for after-sales service returns or pack your machine with a similar cardboard box of the same dimensions.

For any question concerning our after-sales service you can make a request on our website <https://services.swap-europe.com>

Our hotline remains available at +33 (9) 70 75 30 30.



12. WARRANTY EXCLUSIONS

THE WARRANTY DOES NOT COVER:

- Start-up and setting up of the product.
- Damage resulting from normal wear and tear of the product.
- Damage resulting from improper use of the product.
- Damage resulting from assembly or start-up not in accordance with the user manual.
- Breakdowns related to carburetion beyond 90 days and fouling of carburetors.
- Periodic and standard maintenance events.
- Actions of modification and dismantling that directly void the warranty.
- Products whose original authentication marking (brand, serial number) has been degraded, altered or withdrawn.
- Replacement of consumables.
- The use of non-original parts.
- Breakage of parts following impacts or projections.
- Accessories breakdowns.
- Defects and their consequences linked to any external cause.
- Loss of components and loss due to insufficient screwing.
- Cutting components and any damage related to the loosening of parts.
- Overload or overheating.
- Poor power supply quality: faulty voltage, voltage error, etc.
- Damages resulting from the deprivation of enjoyment of the product during the time necessary for repairs and more generally the costs related to the immobilization of the product.
- The costs of a second opinion established by a third party following an estimate by a SWAP-Europe repair station.
- The use of a product which would show a defect or a breakage which was not the subject of an immediate report and/or repair with the services of SWAP-Europe.
- Deterioration linked to transport and storage*.
- Launchers beyond 90 days.
- Oil, petrol, grease.
- Damages related to the use of non-compliant fuels or lubricants.

* In accordance with transport legislation, damage related to transport must be declared to carriers within 48 hours maximum after observation by registered letter with acknowledgement of receipt.

This document is a supplement to your notice, a non-exhaustive list.

Attention: All orders must be checked in the presence of the delivery person. In case of refusal by the delivery person, you must simply refuse the delivery and notify your refusal.

Reminder: The reserves do not exclude the notification by registered letter with acknowledgement within 72 hours.

Information: Thermal devices must be wintered each season (service available on the SWAP-Europe site). Batteries must be charged before being stored.

Energizer®